

DIAMIND | LINE

PHYSICAL CONTAMINATION DETECTION

X-RAY INSPECTION

FOR HORIZONTAL PRODUCTS

EL Series

X-RAY SYSTEMS WITH TOP-DOWN INSPECTION

- For unpackaged products or packaged in flow-pack, cases, trays, etc.
- Not affected by the presence of packaging with metalized poly laminate, tin plate, aluminium, and metalized clips
- Ensures the absence of high-density physical contaminants such as glass, stones, metals, bones, high-density plastic, cement shards, etc.
- Prevents market complaints and recalls, ensuring brand protection
- Manages interconnection in compliance with Industry 4.0
- Quick maintenance and sanitizing thanks to hygienic design

FEATURES

- Intuitive and user-friendly interface
- Image database of rejected products and contaminants' position
- Internal design of custom electronics, including hi-speed sensors
- Easy-opening doors for total access to the inspection area
- A wide range of rejection devices



Easy-opening door



Control panel



MODELS

CODE	SENSOR WIDTH	BELT LENGTH	BELT WIDTH
EL-300	300 mm	1300 - 1800 mm	290 mm
EL-400	400 mm	1300 - 1800 mm	390 mm
EL-500	500 mm	1600 - 2300 mm	490 mm

STANDARD TECHNICAL FEATURES

Control panel	colour touchscreen 15"
Data processing electronics	RISC embedded FPGA
Generator	latest generation – up to 100 W – electronic and integrated cooling module, maintenance not requested
Sensor	RISC embedded FPGA with 0,8 mm pixel - IP65
Self-learning system and Calibration	included
Data and images collection software	included through Ethernet and USB
Kit for remote assistance	included
Compliance industry 4.0	with bidirectional protocol
Conformity	CE, BRC, IFS, HACCP, GMP
Protection degree	IP65

LAYOUT

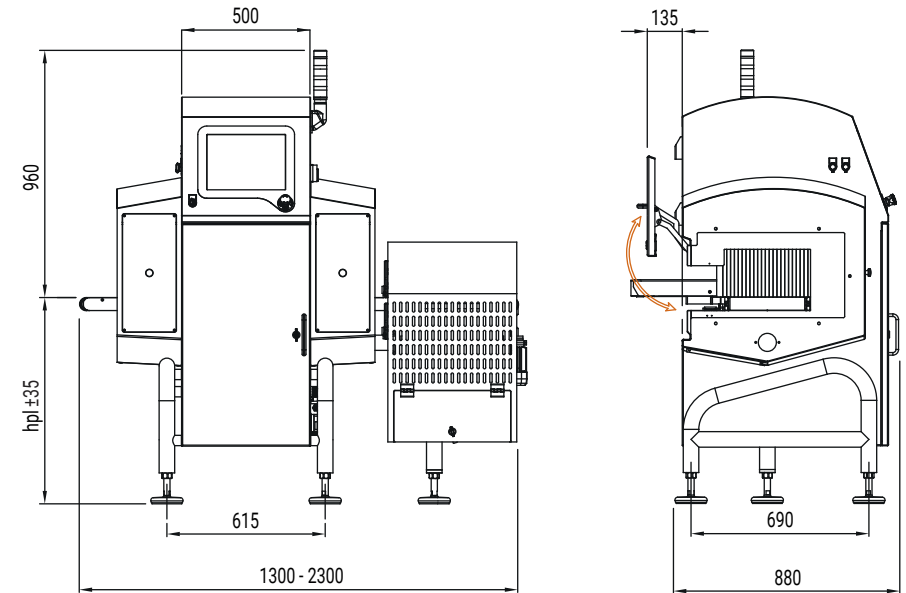

INSPECTION AREA

■ product height ■ product width

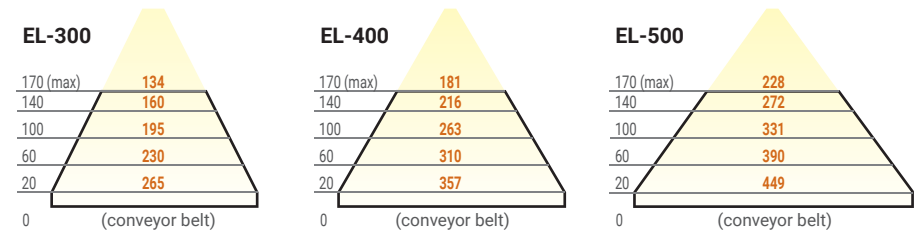

PACKAGING

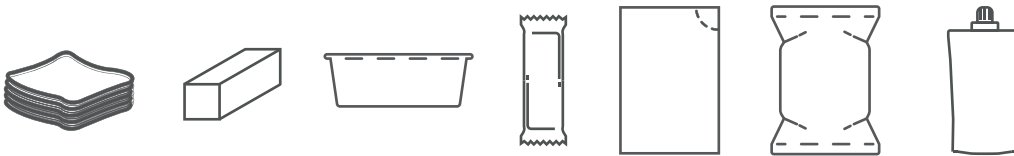

FT System S.r.l.
Via L. Da Vinci, 117 - 29010 Alseno (PC) - ITALY
T. +39 0523 945 745 - info@antaresvisiongroup.com
www.antaresvisiongroup.com



ANTARES VISION
GROUP

EXPERIENCE THE POWER
OF **TRUSTPARENCY**[®]